

1. Mount the Body in place using the screws
2. Ensure the Mixer Body is level
3. Connect water supply and water outlet, test and check for leaks.

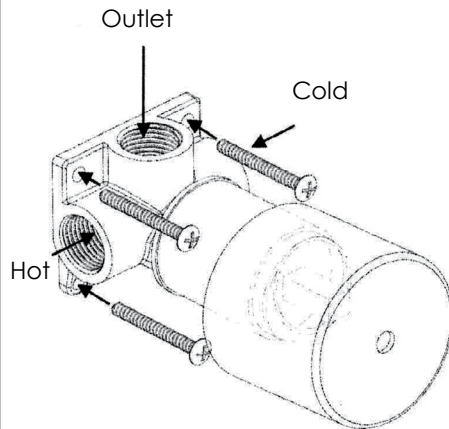

1. Check the back of the Dress plate, measure the size of the Rubber Ring.
2. Create a suitable hole in cement sheet and tiles.
3. Remove the protective cover, push the Dress Plate onto the body.
4. Push on the Handle and fasten Grub Screw.
5. Fit Cap into position.

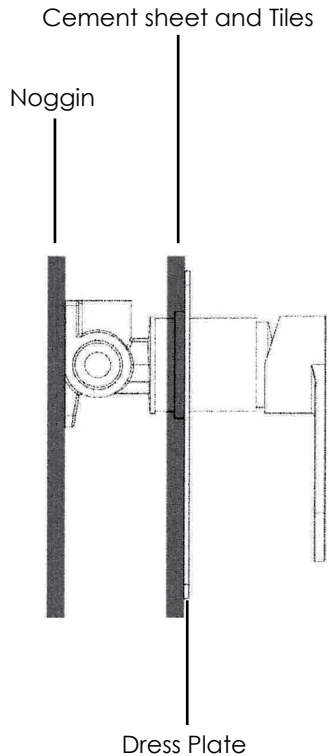
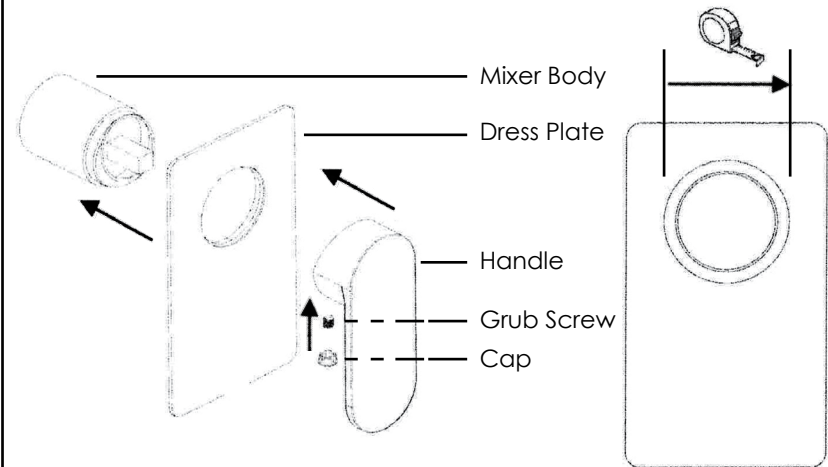

Rubber Ring  
back of the plate



Recommended  
Working Pressure  
150-500KPa  
Maximum Hot  
Water Temperature  
75 degrees

Note:  
 .If the pressure exceeds or likely to exceed 550kpa, an approved pressure limiting device must be installed.  
 .Flush out all pipe work prior to installation.  
 .If the water temperature exceeds 75 °C, an approved tempering valve must be fitted.  
 .Installation should comply with Australian standard AS3500. Failure to comply with the above may void all warranties.

MAINTENANCE AND CARE:  
 .Products should be cleaned with mild liquid detergent or soap and water  
 .Do not use cream cleaners or citrus based cleaning products, as they are abrasive  
 .Use of unsuitable cleaning agents may damage the surface, any damage caused in this way will not be covered by warranty.

DISCLAIMER:  
 .While we aim to ensure the specifications shown are correct at the time of printing, we reserves the right to make modifications without prior notice.