



BASIN SET



SPECIFICATION

PRODUCT CODE	YSW2016-01
WELS RATING	5 STAR 5L/MIN
WATERMARK LICENSE	WM-060073
TEMPERATURE RATING	MIN 1°C-MAX 75°C
PRESSURE RATING	MIN 150KPa-MAX 500KPa

FINISH

	NR201601MB	matt black
	NR201601BG	brushed gold

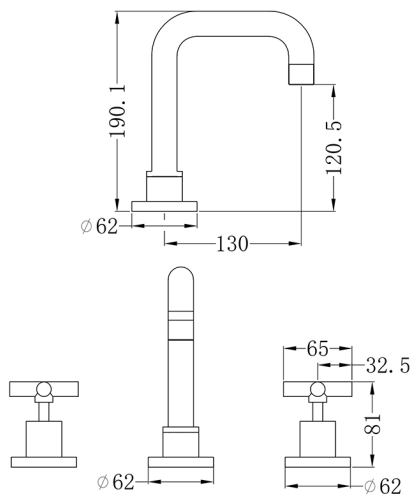

MAINTENANCE AND CARE

All surfaces should be cleaned with mild liquid detergent or soap and water.

Do not use cream cleaners or citrus based cleaning products, as they are abrasive.

Use of unsuitable cleaning agents may damage the surface. Any damage caused in this way will not be covered by warranty.

PACKAGING INCLUDES

- 1x spout
- 2x hand wheel
- 1x mixer body
- 1x installation kit

Dimensions are nominal measurements only.



Versions: 2019.12

1

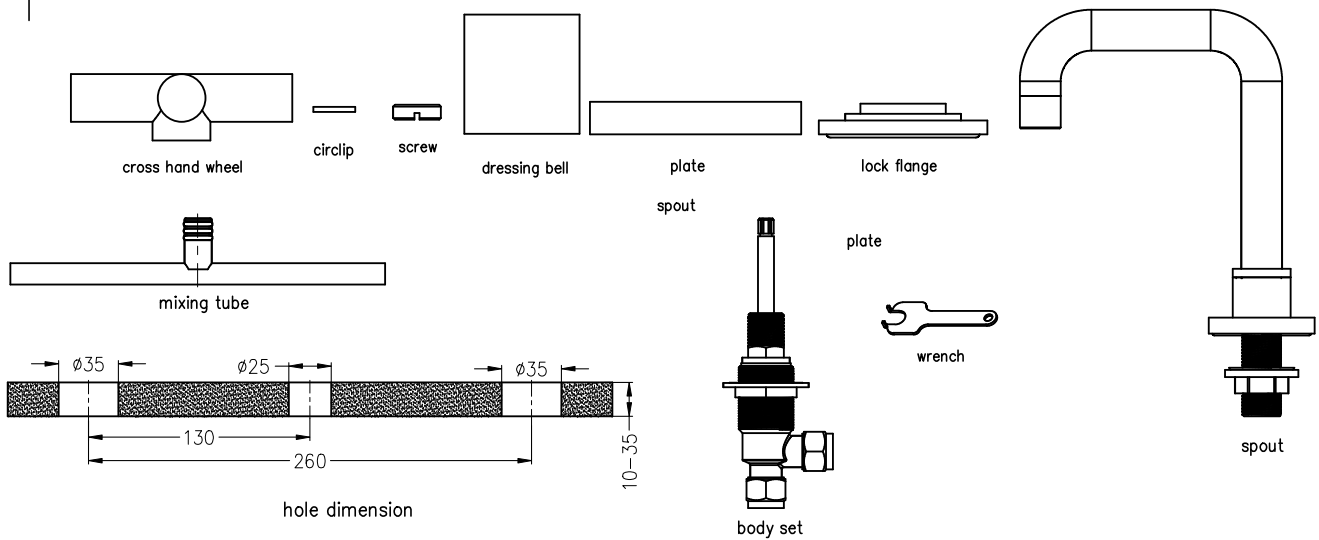

2

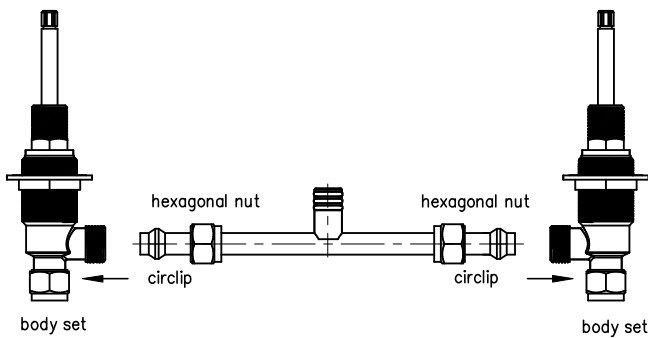

1. Remove the hexagonal nut and circlip from the body set.
2. Put hexagonal nut and circlip on the mixing tube in a row as the picture.
3. Plug the mixing tube into body, and screw hexagonal nut, don't too tight.

3

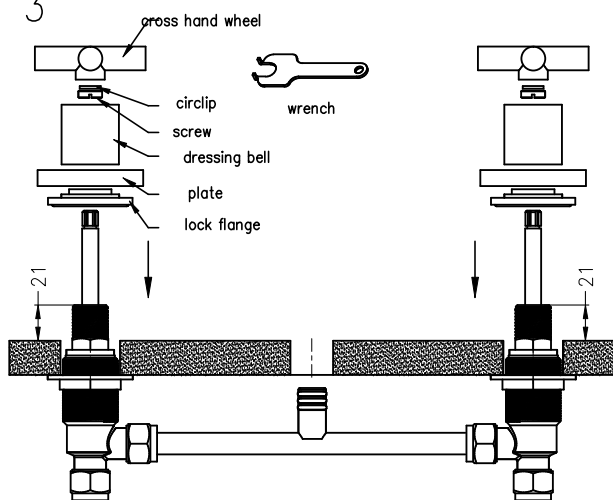

1. Plug the assembled kit (picture 2) from the bottom side of the counter, and adjust the height as the picture.
2. Put on lock flange, and tighten by wrench firmly.
3. Put on plate onto slow-opening valve, then put dressing bell onto valve, and tighten it up.
4. Put the screw onto the stick of slow-opening valve, then put circlip onto gap of slow-opening valve.
5. Put cross hand wheel onto stick of slow-opening valve, then adjust the rotation angle of hand wheel, and tighten it up.

4

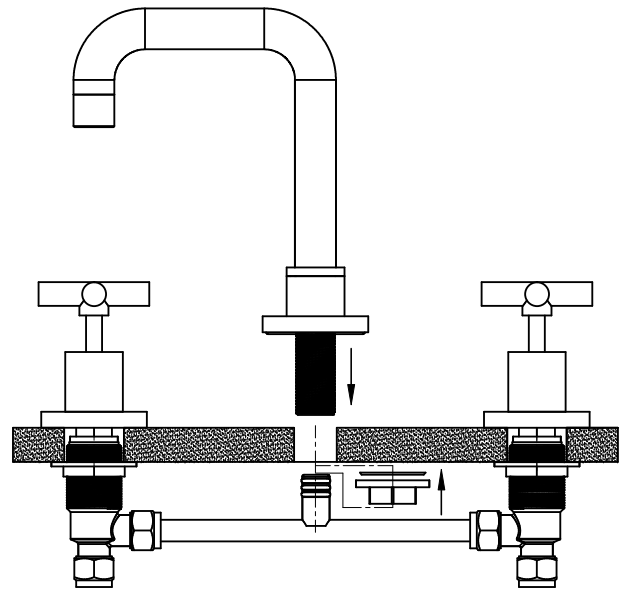

1. Remove the hexagonal nut and washer from the spout.
2. Put the spout in the hole on the counter and put on the washer and hexagonal nut.
3. Put the bottom of the spout onto mixing tube.
4. Tighten the hexagonal nut of spout.
5. Tighten the hexagonal nut beside the body set firmly by wrench.